

NADYTM
AUDIO

OWNER'S MANUAL

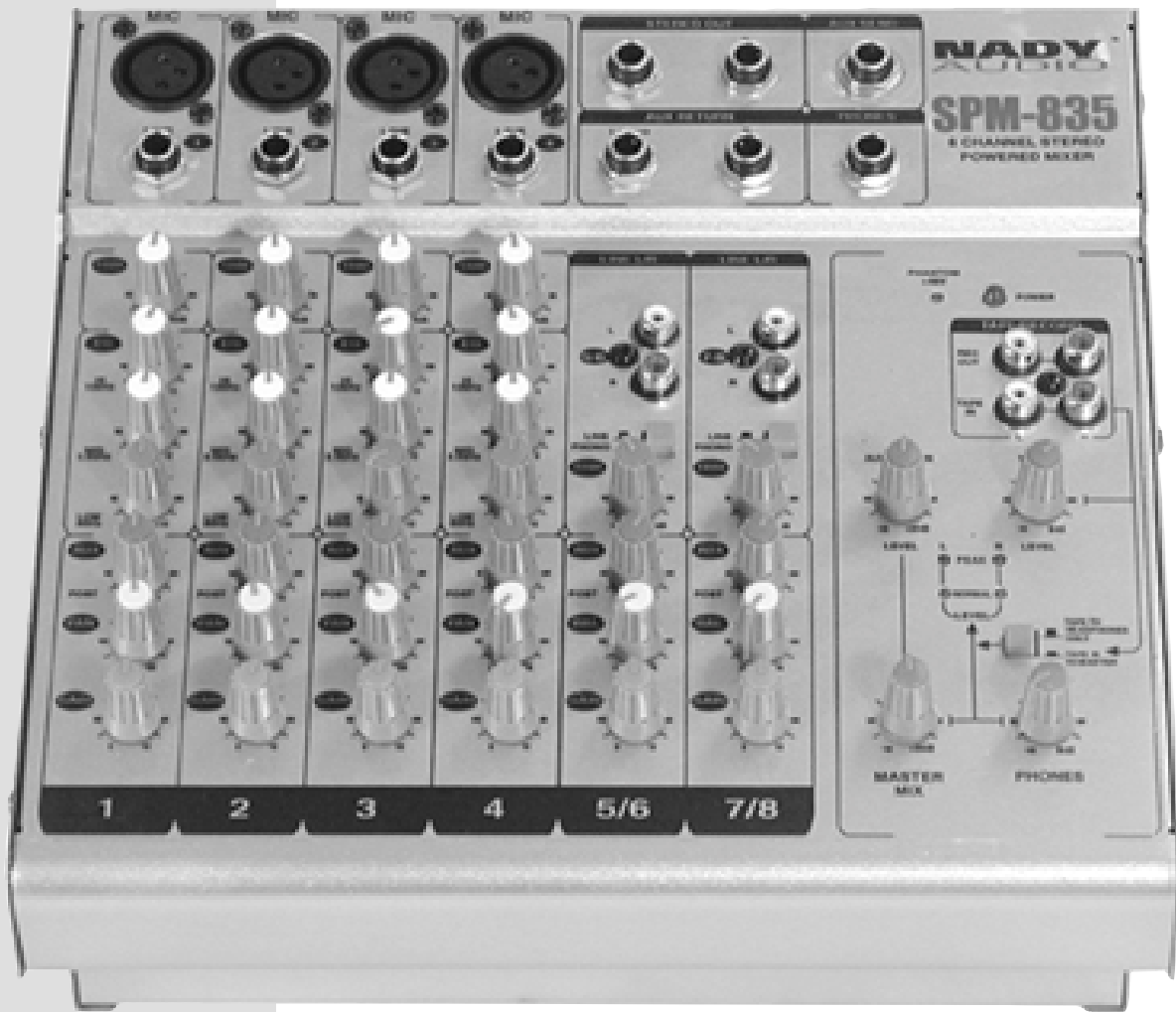

SPM-835

8 CHANNEL STEREO POWERED MIXER

SPM-835

8 CHANNEL STEREO POWERED MIXER



Congratulations!

You have just purchased one of the finest compact powered mixers on the market today. This mixer was developed using the expertise of professional sound engineers and working musicians. You will find your new NADY AUDIO mixer has superior performance and greater flexibility than any other mixer in its price range.

We recommend that you read this manual carefully to get the most out of your new unit. Thanks for selecting NADY AUDIO and the SPM-835 as your choice in powered mixers.

Date of Purchase _____

Dealer's Name _____

City _____

State _____

Zip _____

Model # _____

Serial # _____

CONTENTS

WARNING	3
FEATURES	4
INSTALLATION	5
1. Inspection	5
2. Setup and Operation.....	5
CONTROLS AND CONNECTIONS	6
1. Mono Input Section	6
2. Stereo Input Section.....	7
3. Master Section	8
a. Aux Send>Returns Function and Operation	8
b. Master Mix Function and Operation	9
c. Monitor Function and Operation	10
d. Power Connection and Switches.....	10
4. Connections.....	11
TYPICAL USES AND INSTALLATIONS (FIGURES 1-5)	12
SPECIFICATIONS	14
BLOCK DIAGRAM	15

WARNING

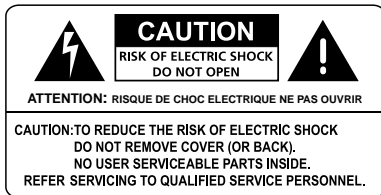

An equilateral triangle enclosing a lightning flash/arrowhead symbol is intended to alert the user to the presence of uninsulated "dangerous voltage" within the product's enclosure which may be of sufficient magnitude to constitute a risk of electric shock.



An equilateral triangle enclosing an exclamation point is intended to alert the user to the presence of important operating and service instructions in the literature enclosed with this unit.

IMPORTANT SAFETY INSTRUCTIONS

When using this electronic device, basic precautions should always be taken, including the following:

1. Read all instructions before using the product.
2. Do not use this product near water (e.g., near a bathtub, washbowl, kitchen sink, in a wet basement, or near a swimming pool, etc.).
3. This product should be used only with a cart or stand that will keep it level and stable and prevent wobbling.
4. This product, in combination with headphones or speakers, may be capable of producing sound levels that could cause permanent hearing loss. Do not operate for a long period of time at a high volume level or at a level that is uncomfortable. If you experience any hearing loss or ringing in the ears, you should consult an audiologist.
5. The product should be positioned so that proper ventilation is maintained.
6. The product should be located away from heat sources such as radiators, heat vents, or other devices (including amplifiers) that produce heat.
7. The product should be connected to a power supply only of the type described in the operating instructions or as marked on the product. Replace the fuse only with one of the specified type, size, and correct rating.
8. The power supply cord should: (1) be undamaged, (2) never share an outlet or extension cord with other devices so that the outlet's or extension cord's power rating is exceeded, and (3) never be left plugged into the outlet when not being used for a long period of time.
9. Care should be taken so that objects do not fall into, and liquids are not spilled through, the enclosure's openings.
10. The product should be serviced by qualified service personnel if:
 - A. The power supply cord or the plug has been damaged.
 - B. Objects have fallen into, or liquid has been spilled onto the product.
 - C. The product has been exposed to rain.
 - D. The product does not appear to operate normally or exhibits a marked change in performance.
 - E. The product has been dropped, or the enclosure damaged.
11. Do not attempt to service the product beyond what is described in the user-maintenance instructions. All other servicing should be referred to qualified service personnel.

FEATURES

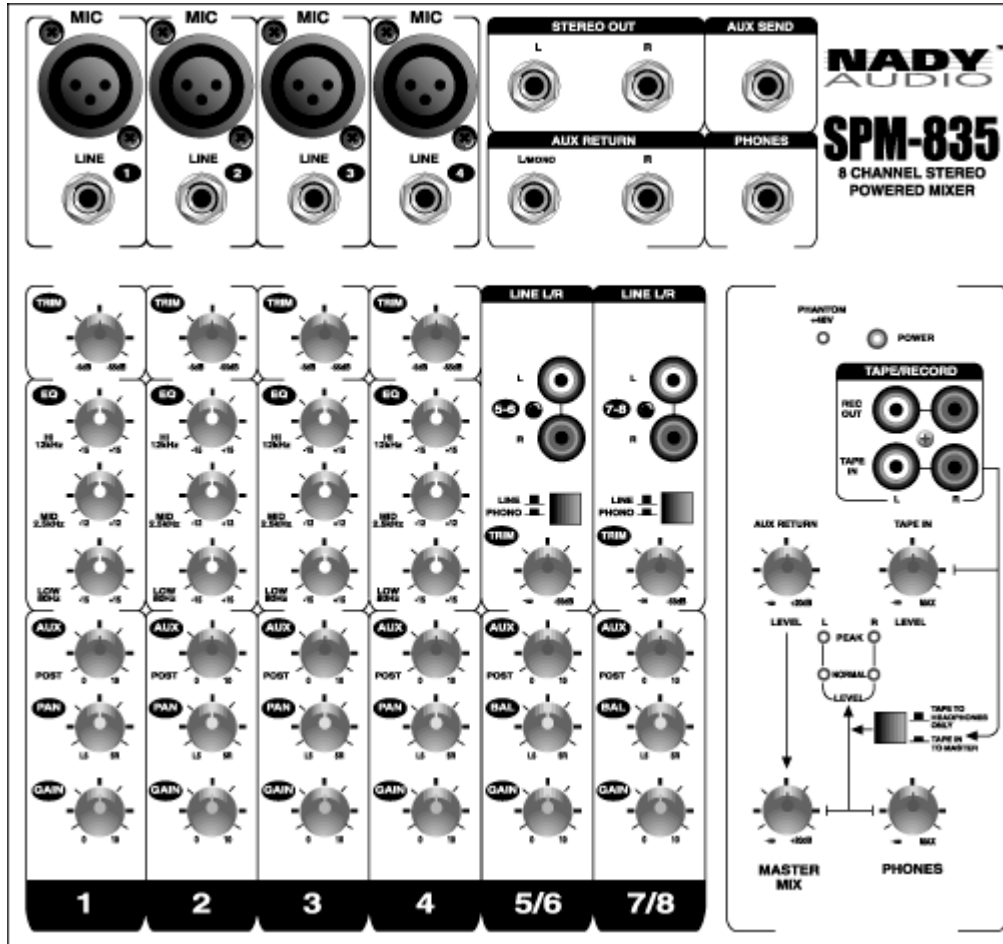

An ultra-compact 35W/channel stereo powered mixer offering top audio performance and exceptional flexibility – perfect for many small venue live sound reinforcement applications.

- Full frequency response, and low noise with a wide dynamic range assures natural transparent audio
- 4 mono balanced XLR mic and unbalanced 1/4" line, and 4 stereo unbalanced RCA jack inputs (8 total inputs)
- Line/Phono level input select switch for stereo channel inputs
- 35W (RMS) @ 4 Ohms stereo speaker outputs
- Stereo Master Mix output (for balanced or unbalanced connection)
- Post-fader Aux Send with Aux level control for external effects and monitoring
- Stereo Aux Return with master Aux Return control
- 3-band active equalizers for mono input channels
- Stereo headphone output with dedicated volume control
- Tape In and Record out RCA jacks with Tape in assignable to Master Mix and Headphone Out or Headphone out only.
- Switchable global +48V phantom power on all mono inputs
- Input Trim control on all mono (1-4) and stereo (5/6, 7/8) channels
- Pan pots on each mono channel and Balance pots on each stereo input
- High quality sealed pots with center detents (Pan/Bal and EQ only)
- LED indicators for Unit On, Normal and Peak operating level metering, and Phantom power on
- All-steel rugged construction for maximum reliability
- Internal AC supply with 140W power consumption
- Dimensions and Weight: 9.9" X 4.5" X 9.6" (252 X 115 X 245mm), 9 lbs (4.1Kg)

INSTALLATION

To ensure years of enjoyment from your NADY AUDIO SPM-835 powered mixer console, please read and understand this manual thoroughly before using the unit.

1. INSPECTION

Your NADY AUDIO SPM-835 was carefully packed at the factory in packaging designed to protect the units in shipment. Before installing and using your unit, carefully examine the packaging and all contents for any signs of physical damage that may have occurred in transit.

(Note: Nady Systems is not responsible for shipping damage. If the unit is damaged, do not return to us, but notify your dealer and the shipping company immediately to make a claim. Such claims must be made by the consignee in a timely manner.)

2. SETUP AND OPERATION

Parts of the unit can become very warm during use. This is normal during operation. Care should be taken to ensure that there is enough space around the unit for cooling (at least 12" or 30cm). Do not place the SPM-835 on high temperature devices such as power amplifiers etc. or the unit may overheat in operation. Also do not place the unit on speakers as this may cause them over a long time to move and fall due to speaker vibrations.

Although the unit's chassis is shielded against radio frequency (RF) and electromagnetic interference (EMI), extremely high fields of RF and EMI should be avoided.

When ready to operate, connect the AC cord to the IEC receptacle and plug into the power source. Be sure to confirm the voltage is proper (115 or 230VAC) for the unit as noted under the AC cord receptacle on the back of the unit. Also make sure that the unit is turned off before connecting to the AC power source. This will avoid possible loud transients which can damage your speakers or your ears, especially when monitoring with headphones.

Set the noted controls to the positions stated below to further minimize the chance of such undesired noises when first powering up your SPM-835 :

LEVEL CONTROLS (7,17)TURN COUNTERCLOCKWISE COMPLETELY

HI, MID & LOW (4)TURN TO THE CENTER POSITION

MASTER & PHONES CONTROLS (17,22)TURN COUNTERCLOCKWISE COMPLETELY

PAN/BAL CONTROLS (6,11)TURN TO THE CENTER POSITION

ALL OTHER CONTROLS SHOULD ALSO BE TURNED COUNTERCLOCKWISE COMPLETELY

Power up the unit as noted in **Power Connection and Switches** (3d in the **Control and Connections** section).

CONTROLS AND CONNECTIONS

1. MONO INPUT SECTION

(1) MIC INPUT

The Mic input is an electronically balanced XLR type designed to accept signals from any balanced low impedance (Low Z) microphone. To accommodate condenser microphones, this input is also equipped with +48VDC phantom power globally switchable to all XLR input jacks with the **Phantom Power switch (28)** on the back panel. Dynamic or ribbon-type microphones do not require phantom powering. It will be necessary to adjust the channel gain with the input **Trim control (3)** to achieve a nominal operating level. The XLR jack is configured for: Pin1 = ground, Pin2 = positive (+), Pin3 = negative (-).

[Note: The Mic inputs are more sensitive than the Line inputs. Also, do not connect mics with the phantom power switched on, as indicated by the **Phantom Power On LED (12)** in the

Master Section of the front panel. Never use unbalanced mic cables with the Phantom Power switched on. Never short the +48VDC to ground, as that can cause serious damage to your mixer. Also, turn down the **Master Mix (17)** to prevent possible sharp transient noise from damaging the speakers when turning the phantom power on or off.]

(2) LINE INPUT

The Line input is designed to accept unbalanced line-level high impedance signals such as those from keyboards, drum machines, or samplers. There is enough gain available on the line input to accept even lower level signals, such as those from an unbalanced microphone or guitar output.

[Note: Only either the Mic or the Line input of a given channel can be connected at one time. Never connect both simultaneously to the same channel.]

(3) TRIM (PAD CONTROL)

The trim control adjusts the input sensitivity (channel gain) of the mic inputs on the mono input channels. This control can be adjusted to accommodate input signals from a wide variety of sources, from the high outputs from keyboards or drum machines to the small signal outputs of microphones. The trim control adjusts the input sensitivity from -5dB to -55dB.

(4) All mono input channels are fitted with a three-band EQ. All three bands have up to 15 dB of cut and boost, with a center detent for "off". The frequency response is flat when all three EQ knobs are in the center detent position. The upper and lower shelving controls have their frequencies fixed at 12 kHz and 80 Hz respectively. The midrange control has a peaking response at 2.5KHz (Q fixed at 1 octave). The channel EQ is a valuable feature of the mixer as it allows the user to control the tonal characteristics of each instrument separately. For example, boosting the LOW can fatten the sound and add punch to the bass or drums; the MID control can be used to define the midrange or bring out the vocals; and adjusting the HIGH control can provide a crisp sounding high end. Another very important, yet often overlooked technique is to use the EQ to subtract from the mix. Cutting the HIGH control can reduce unwanted hiss during multi-track recording, while attenuating the MID or LOW can eliminate feedback in a live performance or clear up a muddy sounding mix. Cutting away the top and bottom, then pushing up the Gain is equivalent to mid range boost!

[Note: Always reset a channel's input Gain (or external devices' output level) after altering the amount of mixer equalization cut or boost applied.]

The key to successful equalization is to avoid excess. Too much equalization on the input channels will result in a mix that is smeared together with nothing specifically defined.

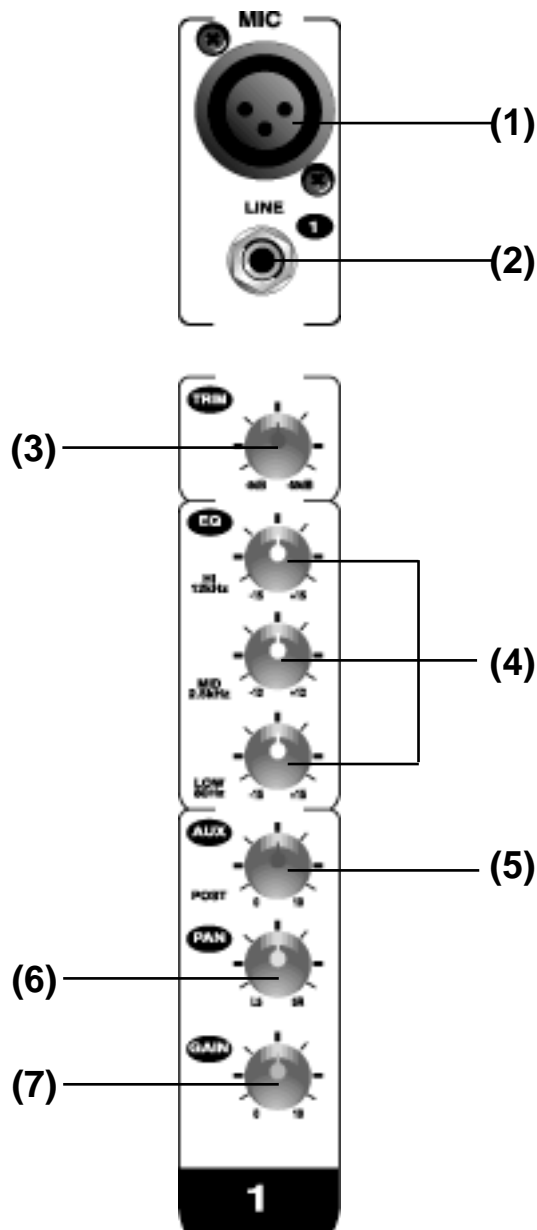

CONTROLS AND CONNECTIONS

During rehearsals, experiment with the equalizer controls on various instruments, vocals and combinations of these mixed together to become familiar with various equalizer settings.

(5) AUX (POST) SEND CONTROL

The Aux send is mono and post-EQ and post-fader and the signal level sent to the AUX bus will be affected by the channel fader setting. This configuration is ideal for almost all effects send purposes. For example, when a fader level is adjusted, any reverb sent from that channel follows the fader. Otherwise, when the fader is pulled down, the reverb from that channel would still be audible. Most reverbs etc. internally sum the left and right inputs so that you can use the mono Aux. You can also use this Aux send to feed inputs to a multi-track recorder or any other unbalanced line level application.

(6) PAN

The Channel Pan positions the output of the channel in the stereo field of the main mix. Its constant-power design ensures there are no level discrepancies whether a signal is hard-panned, center-stage, or somewhere in-between.

(7) CHANNEL GAIN CONTROL

The channel gain controls determine the output signal level to the Master Mix bus. There is no PFL function on the SPM-835. In order to audition any single channel for proper gain, you can turn off the gain control of all the other channels (fully counterclockwise), and set both the auditioned channel and **Master Mix control (17)** to unity gain (0 dB).

2. STEREO INPUT SECTION

(8) L/R LINE INPUTS

On stereo input channels 5-8, the unbalanced RCA jack line inputs are designed for stereo line-level signals such as those from keyboards, drum machines, CD players, tape decks, samplers, or even turntables. However, these inputs can also be used as standard mono line inputs by connecting the signal to the L or R line in. For the stereo inputs, the mono channel **PAN (6)** control is replaced by the BAL (Balance) control. See also **BAL CONTROL (11)** below.

When using channels 5-6, 7-8 as stereo input channels, the left signal should be connected to the L input and the right signal to the R input. These signals will be routed to the AUX, EQ and Channel Gain controls equally and will retain their stereo separation. The AUX, EQ, BAL, and Channel Gain controls all function the same as those on the mono input channels. When a stereo signal is input to a stereo input channel, these controls will affect the left and right signals equally.

(9) LINE/PHONO INPUT SELECT SWITCH

Place this switch in the “up” position for line level inputs such as from instruments, CD, players, tape machines, DAT players, etc. Press the switch to the “down” position for a phono level input such as a DJ turntable.

(10) TRIM

The trim control for the stereo input channels functions the same as the control for the mono inputs. This control can be adjusted to accommodate input signals from a wide variety of sources, from the high outputs from keyboards or drum machines to the small signal outputs of microphones. This wide range eliminates the need for Mic/Line switching. The trim control adjusts the input sensitivity from $-\infty$ to -55dB .

(5) AUX SEND

These are the same as for the mono channels. Note that a mono sum is taken from the stereo input.

(11) BAL CONTROL.

For a mono input to the L or R input the function of the control is the same as the **PAN controls (6)** of the mono channels. However, when a channel is run in stereo, this control functions as a Balance control, determining the relative Balance of the left and right channel signals being sent to the left and right Master Mix buses.

For example, with the Balance control turned fully clockwise, only the right portion of the channel's stereo signal will be routed to the Master Mix.

(7) CHANNEL GAIN CONTROL

This has the same function as the mono channels. See **Mono Input Section**.

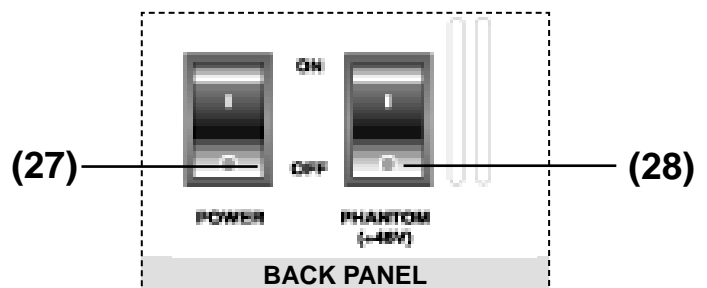
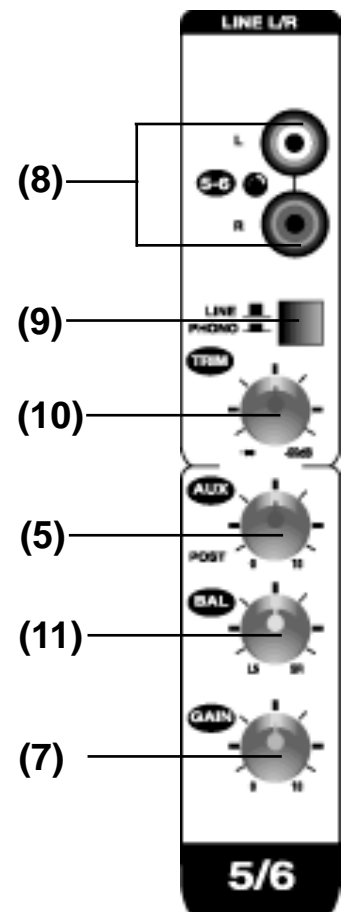

CONTROLS AND CONNECTIONS

3. MASTER SECTION

a. AUX Send>Returns Function and Operation

- (24) STEREO AUX RETURNS (LEFT/MONO, RIGHT)
- (16) AUX RETURN CONTROL

The Aux Return jacks are the mono or stereo returns for **Aux Send (25)**. If you connect a signal to the Left/Mono Return jack only, the Aux Return will operate in mono and the signal will be routed to the **Aux Return Control (16)** and then mixed into the left and right **Master Mix Stereo Outputs (23)**. The separate left and right return jacks are provided for use with stereo signals such as those from the output of a stereo effects processor. The left and right return signals will be routed to the **Aux Return level control (16)** and mixed into the left and right **Stereo Out (23)**, while maintaining stereo separation. The Aux Returns are multi-functional. They may be used for returning the outputs of effect units, such as Tape Returns from a multi-track recorder, or as extra instrument inputs, especially if your MIDI keyboard or rack supplies a pre-mixed stereo signal. Certain stereo effects produce a perceived imbalance between the left and right channel levels. To correct for this you will have to bring your stereo effect back on a stereo channel, which has a **Balance control (11)**. When applying short left and right delays, the shortest one will always seem loudest. When pitch shifting up and down in wide stereo to thicken a sound, the signal shifted upwards will seem louder than one that goes down. In both cases use the Balance control to compensate. When performing any stereo imaging exercise, don't just rely on the control room monitors. Get a pair of headphones and listen in stereo and in reverse stereo, just in case you have any significant hearing discrepancies. Sometimes you might want

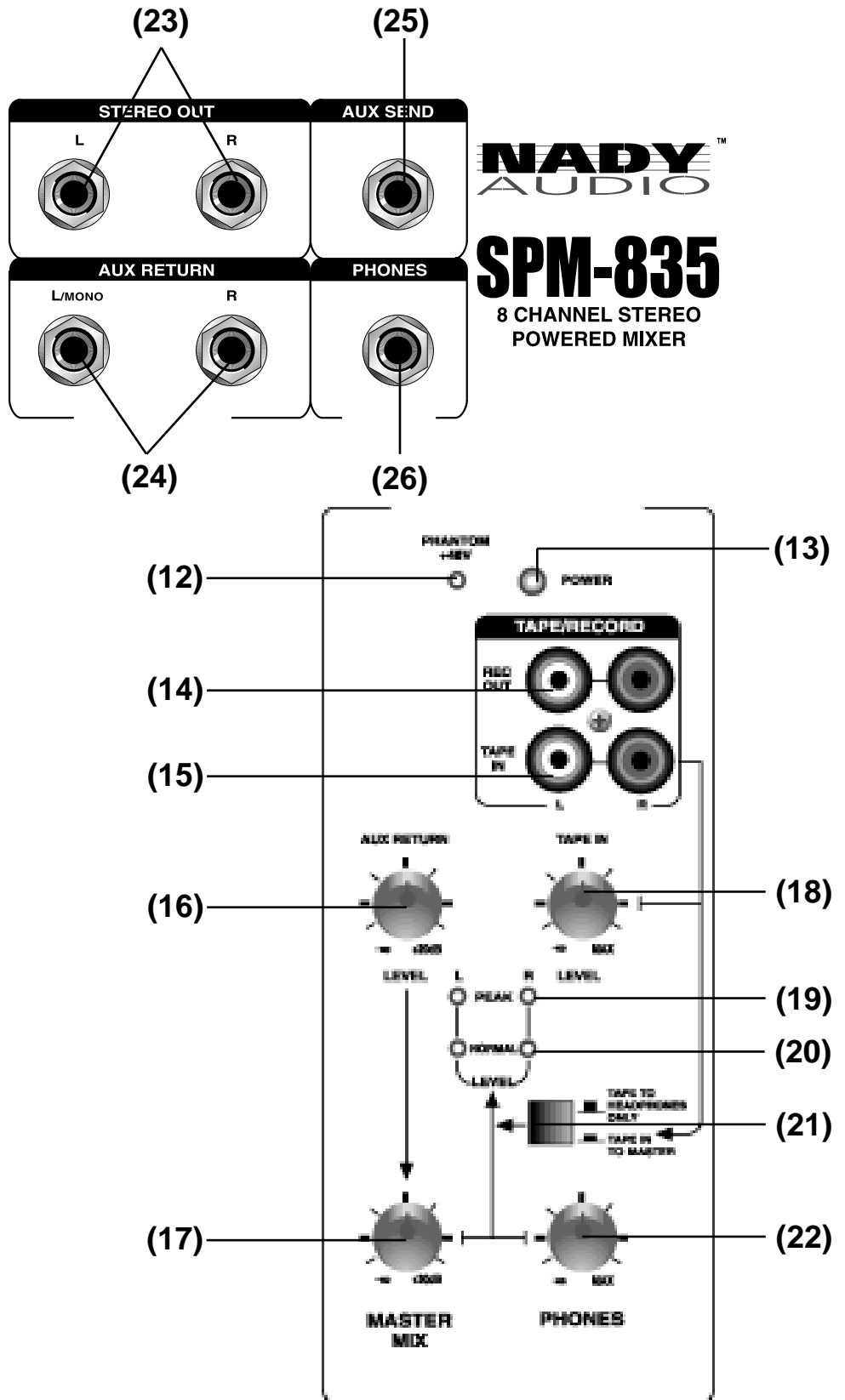

CONTROLS AND CONNECTIONS

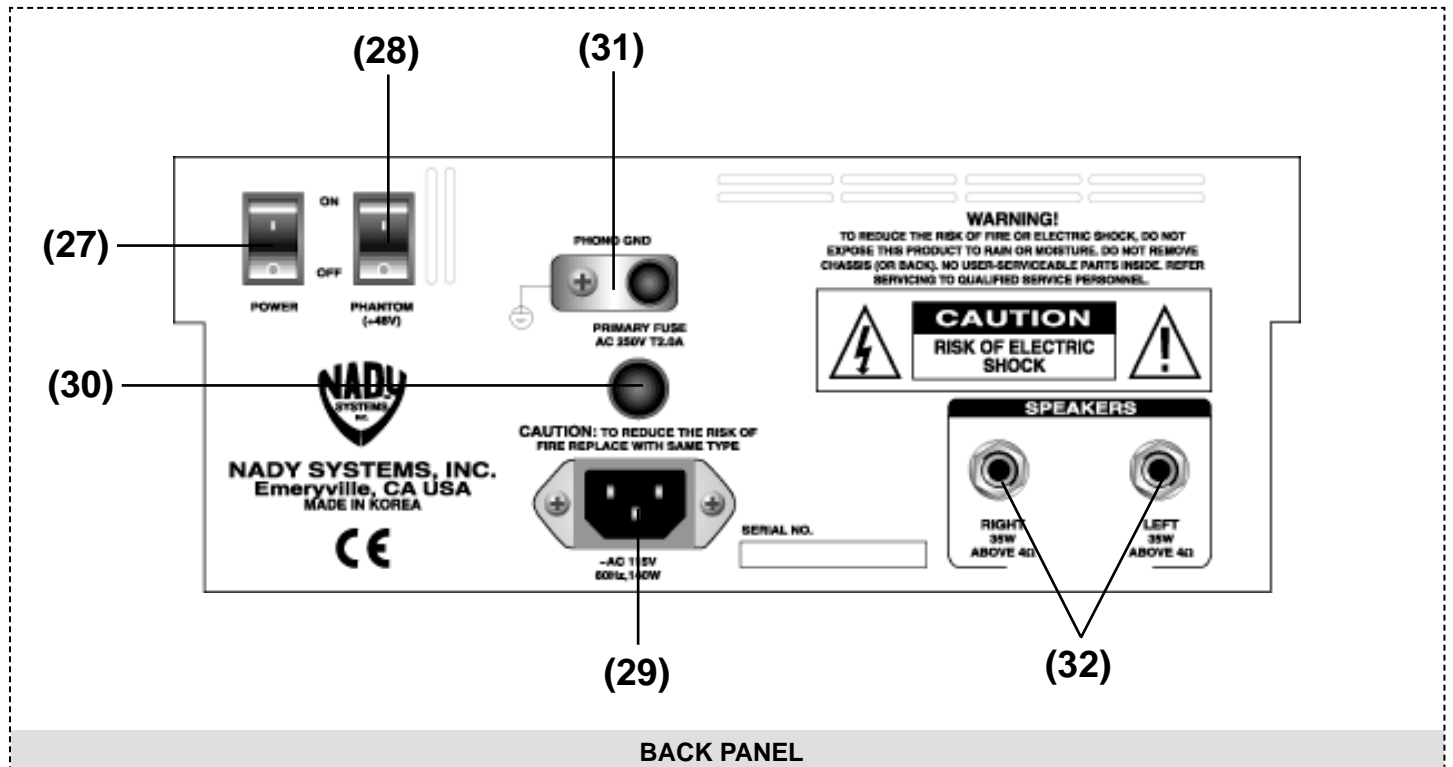

to narrow the stereo width of a reverb field. To do this you will have to come back on two mono channels to get independent pan for the left and right signals.

(25) AUX SEND

The Aux Send jack is the unbalanced output for the signals sent from the channel **Aux controls (5)**. It is post-fader. This signal can be sent to the input of an effects processor, multi-track recorder, or used for any other line-level auxiliary purpose. The Aux Send level is adjusted by the channel **Aux Send controls (5)**.

(12) PHANTOM POWER ON LED INDICATOR

This LED will light when the **PHANTOM POWER switch (28)** is turned on.

(13) POWER ON LED

Once you have connected the AC power cord to the AC power source and the **AC Power In Socket (29)**, switch on your mixer with the **Power On switch (27)**. The Power "ON" LED will light up. Allow 1 minute after powering up for the system to reach equilibrium before setting input gains and other levels.

b. Master Mix Function and Operation

(32) MAIN SPEAKER OUTPUTS

(23) STEREO OUTPUTS

(15) TAPE INPUTS

(18) TAPE IN LEVEL CONTROL

(14) REC OUTPUTS

(17) MASTER MIX GAIN CONTROL

(19,20) LED OUTPUT METERING INDICATORS

(21) TAPE IN TO MASTER/TAPE TO HEADPHONES ONLY SWITCH

The Master Mix is output to the **Main Speaker outputs (32)**, **Stereo Outputs (23)**, and the **Record Output (14)**. The **L/R Speaker Outputs (32)** provide 35W at 4 ohms for powering P.A. speakers rated for this power or more. The Stereo Outputs are Left (L) and Right (R) 1/4" TRS phone jacks compatible with both unbalanced and balanced connections to other mixers, recording equipment, or additional amplifiers for increased P.A. power, etc. The **REC Outputs (14)** also provide an output of the master mix. These outputs are RCA jacks, and designed primarily for inputs to tape recorders, etc. The output level routed to the Speaker outputs, Stereo Outputs and REC Outputs is determined ultimately by the setting of the **Master Mix Gain Control (17)**. The Master Mix (signal on the main bus) is the sum of the signals routed from all the channels and also the inputs from the AUX return bus and the **TAPE Input (15)**. Set the **Tape In To Master/Tape to Headphones Only switch (21)** to the "down" position to route signals from the **Tape Input (15)** to the **Master Mix Gain Control (17)**. The level of signal routed to the **Master Mix Gain Control (17)** from DAT, tape decks, CD players, etc., input to the **Tape Input (15)** is determined by the setting of the output volume control of the audio device

CONTROLS AND CONNECTIONS

being connected and the **Tape In Level Control (18)**, so care must be taken in adjusting these levels so as to achieve proper balance in the final mix and to prevent overload distortion. The **LED Output Metering Indicators (19, 20)** can be used to maintain proper levels in the master mix. The **L/R Normal LED Indicators (20)** will light to indicate normal operating levels and you should always try to keep your levels within this range. Overload is indicated by the **L/R Peak LED indicators (19)**. The Peak LEDs will light when the master mix is going into overload. It detects the peak level and will illuminate at 3dB before clipping to warn that the signal is approaching overload. You do not want the Peak LED to light except very intermittently during a take or a mix. If it does light persistently, reduce the master mix gain with the **Master Mix Gain Control (17)**.

c. Monitor Function and Operation

(26) HEADPHONES OUTPUT

(22) PHONES LEVEL CONTROL

(21) TAPE IN TO MASTER/TAPE TO HEADPHONES ONLY SWITCH

The SPM-835 allows you to monitor the Main Master Mix. The signal level is adjusted with the **Phones Level control (22)** and routed to the **Headphones (26)** output. The **Phones Output (26)** will feed headphones and is a 1/4" TRS jack, wired: tip = left signal, ring = right signal, sleeve = ground. (Note: Use only headphones with an impedance >50 Ohms or you may experience some distortion.) If desired, this output can also be connected instead to an amplifier and speakers for control room or stage monitoring. The **Tape In To Master/Tape To Headphones Only Switch (21)** can be set to the "up" position to route the signal input to the **Tape In jacks (15)** to the headphones for selective monitoring of the Tape In signal only.

d. Power Connection and Switches

(29) AC POWER IN SOCKET

(27) MAIN POWER SWITCH

(13) POWER ON LED INDICATOR

(30) FUSE HOLDER

(31) PHONO GROUND TERMINAL

Check the power source for the proper voltage (115VAC or 230VAC) noted below the **Power In Socket (29)**. Once you have connected the AC power cord to the AC power source and the **AC Power In Socket (29)**, switch on your mixer with the **Power On switch (27)**. The **Power "ON" LED (13)** will light up. Allow 1 minute after powering up for the system to reach equilibrium before setting input gains and other levels. You can leave the SPM-835 on all the time. It is conservatively designed, so heat build up isn't a problem even in 24-hour-a-day operation. There's nothing that will burn out or get used up. Alternatively, you can just plug every unit in your total

system into a Nady power conditioner PCL-800/810/815 or a good quality power strip, for one-button turn-on.

If you are using a turntable in your setup it is a good idea to connect its ground to the **Phono Ground Terminal (31)** to avoid hum and/or possible shock. The SPM-835 is fused for your (and its own) protection. If a fuse blows, disconnect the AC cord, and replace the fuse with a 2.0A SLO-BLO (5x20mm 250V), available at electronics stores or your dealer (or a 1.0A SLO-BLO, 5x20mm 250V, if your SPM-835 is a 220V-240V unit). If the fuse blows continuously upon replacement, unplug the unit and refer to qualified personnel for servicing before further use.

(28) PHANTOM POWER SWITCH

(12) PHANTOM POWER ON LED INDICATOR

When using condenser mics, +48VDC can be switched globally on or off to the XLR mic inputs for all mono channels (also see **MONO INPUT SECTION, MIC INPUTS**). When this switch is in the "ON" position, the **Phantom Power On LED Indicator (12)** will light, and +48VDC will be provided between pins 2 and 3 of all the mono Mic input XLR connectors. If you don't need phantom power, be sure to turn this switch to the "OFF" position.

*[Note: It is safe to connect balanced dynamic mics or line level devices even if this switch is on, but connecting unbalanced devices or devices whose transformers are center-grounded will cause hum or malfunctions. Shorting the +48VDC can also damage your mixer. Also, turn down the **Master Mix control (17)** to prevent possible sharp transient noise from damaging the speakers when turning the phantom power on or off.]*

CONNECTIONS

This NADY AUDIO powered mixer uses 4 different types of audio connectors for the various input/output connections: (1) XLR balanced; (2) 1/4" TRS phone jacks for balanced, unbalanced, stereo, or in/out inserts; (3) 1/4" TS unbalanced; (4) RCA pin unbalanced

Figures

1. *Balanced XLR input/output connections*
2. *Stereo headphone connection with 1/4" TRS plug*
3. *1/4" mono (TRS) plug used as unbalanced input/output*
4. *1/4" stereo (TRS) plug used as balanced input/output*
5. *1/4" TRS plug used as Insert Send/Return*
6. *RCA pin plug for unbalanced input/output*

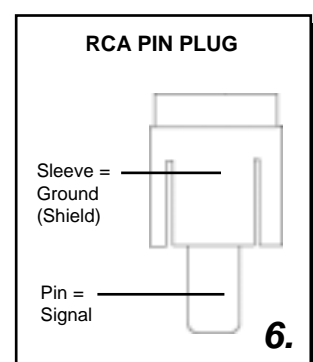
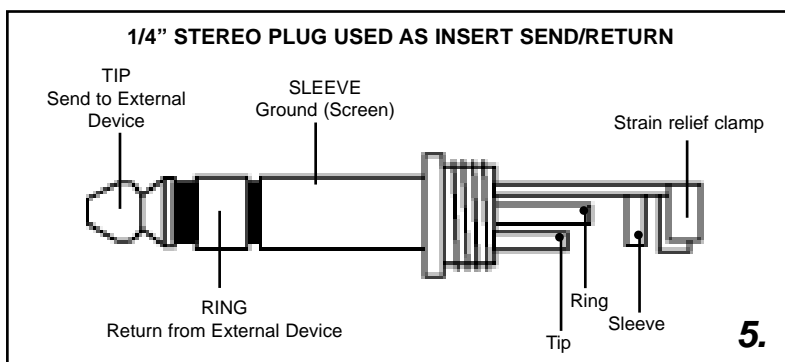
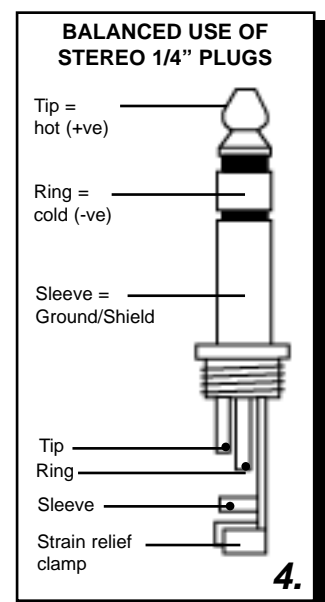
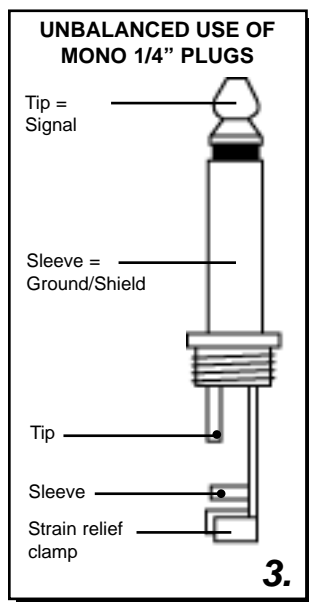
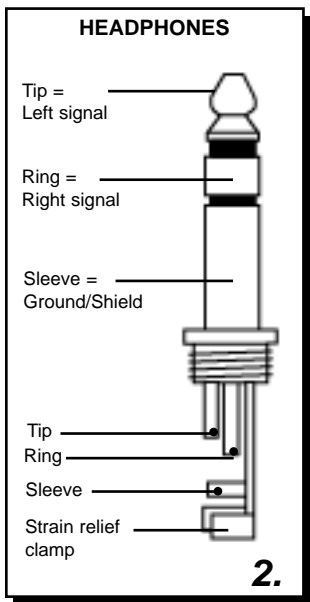
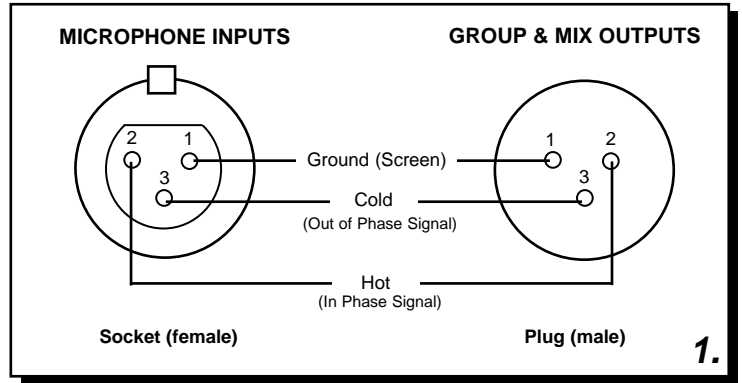

TYPICAL USES AND INSTALLATIONS

PRESENTATIONS

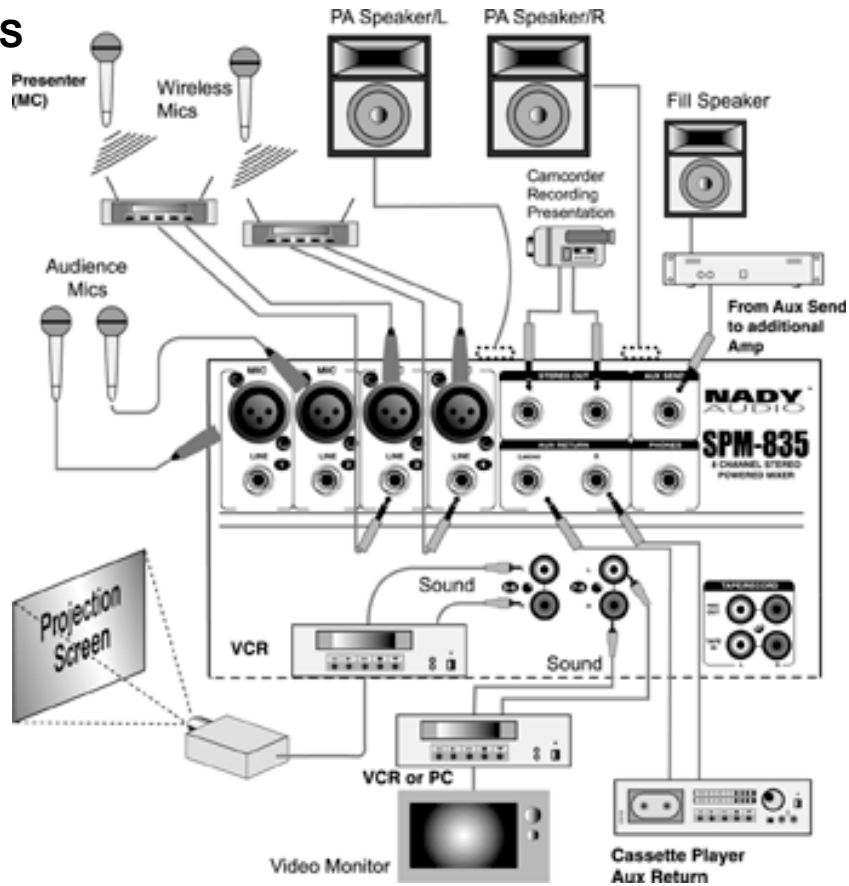

SMALL P.A.

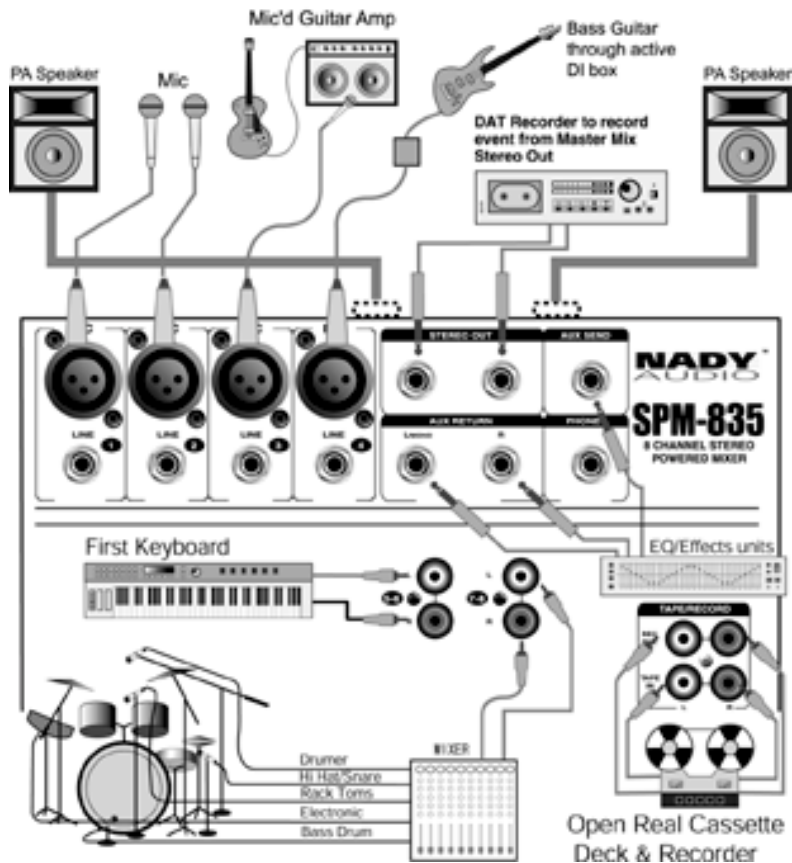

TYPICAL USES AND INSTALLATIONS

REHEARSALS & RECORDING to PORTASTUDIO

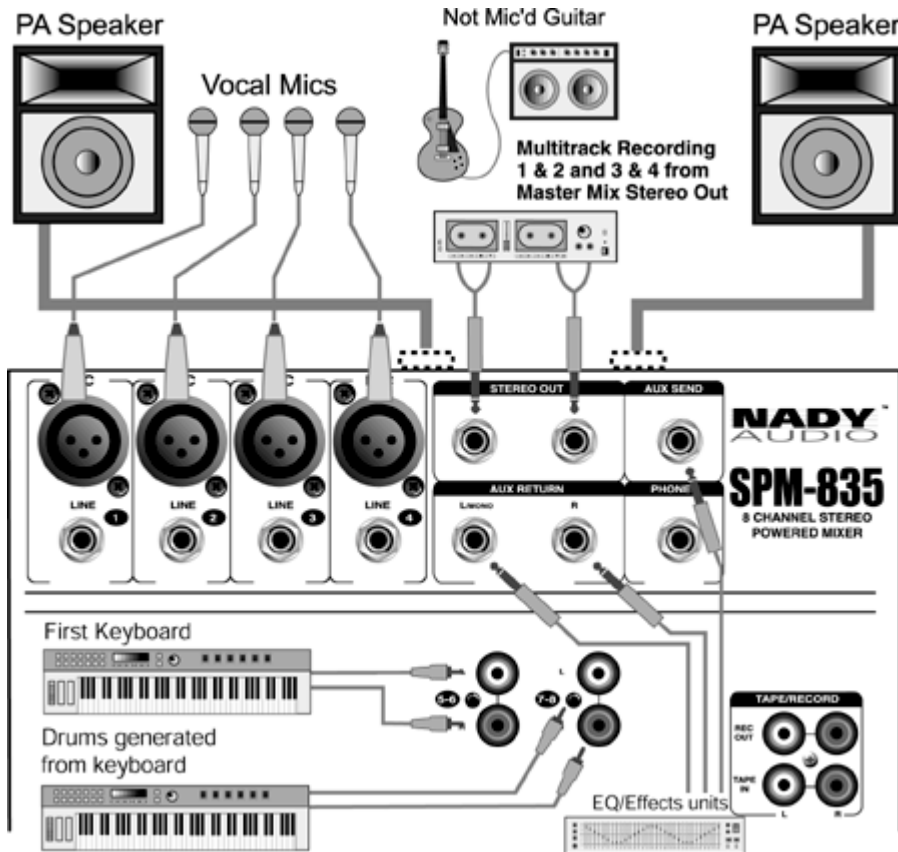

MULTIMEDIA

OUTDOOR EVENT

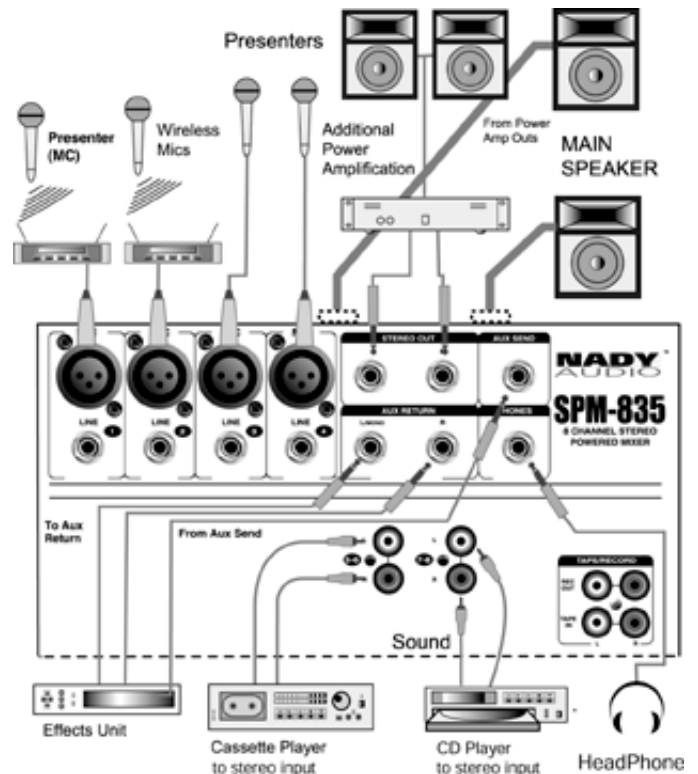
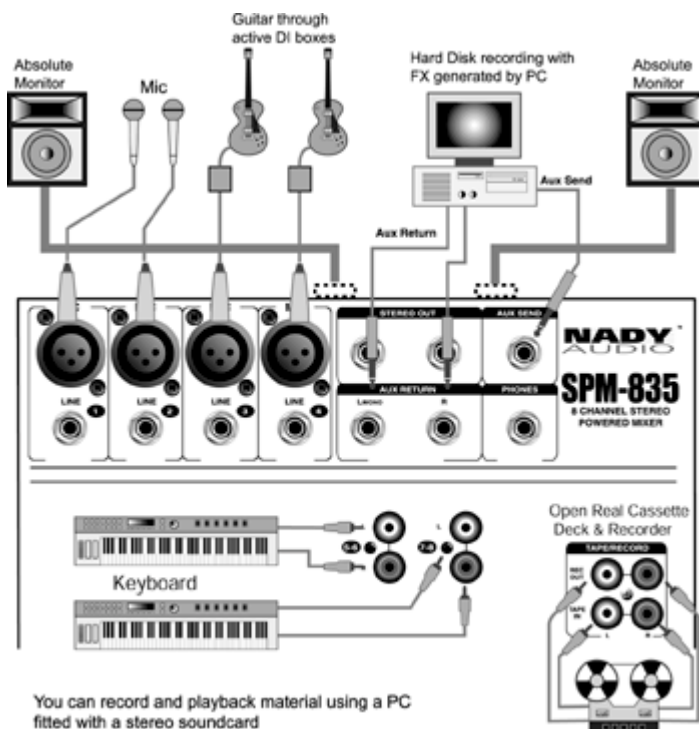

SPECIFICATIONS

1. POWER OUTPUTS (R.M.S)

70 Watts (35W + 35W) /4Ω x 2
0.1% (T.H.D) @ 1KHz

2. TOTAL HARMONIC DISTORTION

Main Amp ≤ 0.05% @1KHz
Mic Ch ~ Main Amp ≤ 0.1% @1KHz

3. FREQUENCY RESPONSE

± 3dB, 20Hz ~ 20KHz @ 1W/4Ω (Speaker Output)
± 3dB, 20Hz ~ 20KHz @ +4dB/10Ω (Mixer Stereo Output)

4. INPUT LEVELS

MIC CH-55dBv
LINE CH.....-20dBv / -50dBv (PHONO)
TAPE IN -20dBv
AUX RETURN -20dBv @ Rs = 150Ω (20Hz ~ 20KHz)

5. HUM & NOISE

≤ -80dB ("A" FILTER)

6. REMAINING NOISE

≤ -85dB ("A" FILTER)

7. INPUT CHANNEL EQUALIZATION

MIC, LINE, & PHONO INPUTS:

EQ

HIGH (Shelving)12KHz / ±15dB
MID (Bell)2.5KHz / ±12dB
LOW (Shelving)80Hz / ±15dB

8. HEADPHONE OUTPUTS

200mW

9. PROTECTION

TURN ON MUTING ~ 1 SEC
TURN OFF MUTINGINSTANT

10. PHANTOM POWER

+48VDC, globally selected

11. POWER REQUIREMENTS

As Noted on Unit115VAC/60Hz, 230VAC/50Hz

12. POWER CONSUMPTION

140W

13. FUSE

115VAC Operation2.0A SLO-BLO, 5x20mm, 250V
230VAC Operation1.0A SLO-BLO, 5x20mm, 250V

14. DIMENSION (W x H X D)

9.9" x 4.5" x 9.6" (252 x 115 x 245 mm)

15. WEIGHT

9 lbs (4.1 Kg)

The specifications are as above at the time of printing this manual. For improvement purpose, all specifications, design and appearance subject to change without prior notice.

BLOCK DIAGRAM

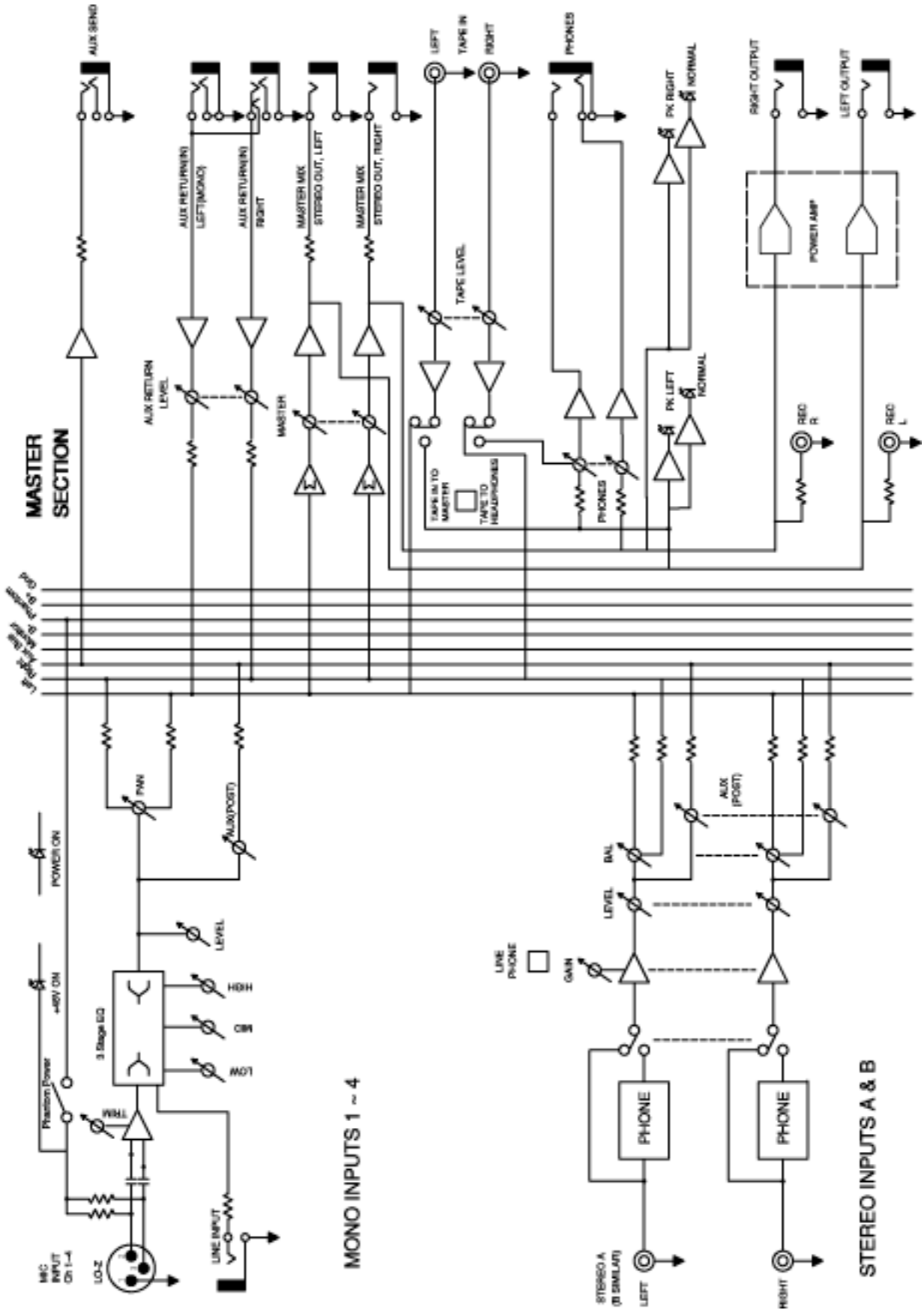

SERVICE FOR YOUR NADY AUDIO PRODUCT

(U.S.) Should your NADY AUDIO product require service, please contact the Nady Service Department via telephone at (510) 652-2411 or e-mail at service@nadywireless.com.

(International) For service, please contact the NADY AUDIO distributor in your country through the dealer from whom you purchased this product.

DO NOT ATTEMPT TO SERVICE THIS UNIT
YOURSELF AS IT CAN BE DANGEROUS
AND ALSO WILL VOID THE WARRANTY.

